



Clarke, B., 2014. "John Lilly, The Mind of the Dolphin, and Communication Out of Bounds."
communication +1, vol 3, iss 1,
DOI: 10.7275/R5RB72JG



John Lilly, The Mind of the Dolphin, and Communication Out of Bounds

Bruce Clarke, Texas Tech University, brunoclarke@gmail.com

In this essay I develop a systems-theoretical observation of John Lilly's cybernetics of communication in his 1967 work *The Mind of the Dolphin*. The eight-year-old project that *The Mind of the Dolphin* recounts for public consumption details his aspiration to achieve an unprecedented breakthrough beyond companionate communion to fully abstract linguistic communication across species boundaries. Between 1959 and 1968 Lilly wagered and lost his mainstream scientific career largely over this audacious, ultimately inconclusive bid to establish and document for scientific validation "communication with a nonhuman mind." In that effort, however, he mobilized the best available tools, a cutting-edge array of cybernetic concepts. He leaned heavily on the information theory bound up with first-order cybernetics and operated with heuristic computational metaphors alongside the actual computers of his era. As I will elicit through some close readings of his texts, in that process Lilly also homed in on crucial epistemological renovations with a constructivist redescription of cognition that may have influenced and motivated his colleague Heinz von Foerster's more renowned formulations, arriving in the early 1970s, of a *second-order cybernetics*.

Keywords: communication, cybernetics, John Lilly, Heinz von Foerster, systems theory

Since his death at the age of eighty-six in 2001, one can detect a bit of an upsurge of scholarly interest in John C. Lilly, M.D.¹ Up until the present millennium, Lilly would have been deemed more notorious than renowned, remembered more often for his later exploits as an extreme psychonaut than for the scientific career leading up to those self-documented “autobiographies of inner space.” However, that notoriety followed upon a period of national prominence as a behavioral physiologist turned dolphin researcher and well-received author of the popular scientific volumes *Man and Dolphin* (1961) and *The Mind of the Dolphin: A Nonhuman Intelligence* (1967). Then, in a series of professional and personal memoirs spanning the 1970s—including his first research report on psychedelic self-exploration, *Programming and Metaprogramming in the Human Biocomputer* (1969), as well as *The Center of the Cyclone: An Autobiography of Inner Space* (1972), *The Dyadic Cyclone: The Autobiography of a Couple*, co-written with Antonietta Lilly (1976), and *The Scientist: A Novel Autobiography* (1978)—Lilly chronicled his own transition from lion of the international scientific mainstream to psychic pioneer scouting the cosmic reaches of the American counterculture.

The primary theme I will use to map a route through a small selection of Lilly’s multifarious writings and personal transformations at the cusp of his mid-life transition is communication. When Lilly left his position as section head at the National Institutes of Mental Health (NIMH) in 1958 to concentrate on dolphin research, he named the private scientific operation he founded, with an office in Miami, Florida, and laboratories on the island of St. Thomas, the Communication Research Institute (CRI). While at the NIMH, Lilly had invented the isolation tank, the flotation chamber and sensory-deprivation device eventually made famous in the movie *Altered States*. In the mid-1950s Lilly embarked on a prolonged course of experimentation, largely upon himself, exploring the psychic states to be discovered floating in the tank. These

¹ See Nicolas Langlitz, “Tripping in Solitude: Introducing Honza Samotar by Way of John Lilly,” in Katrin Solhdju, ed., *Introspective Self-Rapports: Shaping Ethical and Aesthetic Concepts 1850–2006* (Preprint 322) (Berlin: Max Planck Institute for the History of Science, 2006), 81-92; and Langlitz, *Neuropsychedelica: The Revival of Hallucinogen Research since the Decade of the Brain* (Berkeley: University of California Press, 2013), 215-17; Jeff Pruchnic, “Neurorhetorics: Cybernetics, Psychotropics, and the Materiality of Persuasion,” *Configurations* 16: 2 (Spring 2008), esp. 186-94; D. Graham Burnett, *The Sounding of the Whale: Science and Cetaceans in the Twentieth Century* (Chicago: University of Chicago Press, 2012), 516-670; and John Shiga, “Of Other Networks: Closed-World and Green-World Networks in the Work of John C. Lilly,” *Amodern* 2: *Network Archaeologies*, <http://amodern.net/article/of-other-networks/>.

researches formed a parallel experimental track during the years of dolphin research at CRI, from 1959 to 1968. His applications of LSD within both research programs began only in the mid-1960s. But their effects, I speculate, were instrumental in the way that his communications research devoted to interspecies exchange with dolphins eventually lapsed as he pursued a post-scientific round of therapeutic, sociopolitical, epistemological, and cosmological messages for his fellow humans. Lilly's scientific purpose of theorizing communication through experiments testing its species boundaries developed into the narration of phenomenal events beyond the bounds of any common human experience. However, in the period of the later 1960s I will focus on, Lilly's theorizations of communication arrived at innovative applications of first-order cybernetics and information theory. I will be particularly concerned to develop a systems-theoretical observation of Lilly's cybernetics of communication in *The Mind of the Dolphin*.

The Mind of the Dolphin

On October 24, 1967, Heinz von Foerster, the director of the Biological Computer Laboratory (BCL) in the Department of Electrical Engineering at the University of Illinois, prepared to send John Lilly a packet of professional correspondence. His cover letter began: "Dear John, I cannot tell you how grateful I am for your sending me your Eighth Annual Report. It gives me new fuel for my perpetual admiration of your work—if this refueling were necessary at all."² To tell from von Foerster's letter, it covered his own summary of recent BCL activities and some BCL reprints and lab reports with an explanation that clarifies to some extent the object of his admiration: "For us, your work on inter-species symbolic discourse was most significant in developing the concepts we tried to formulate." Von Foerster's packet also included a \$5.00 check in response to a book notice Lilly had sent along for his popular trade volume just released by Doubleday, *The Mind of the Dolphin: A Nonhuman Intelligence*.³

The Mind of the Dolphin is no light read. The preface declares that its "main ideas and formulations are a theory to scientifically penetrate into the area of at least one nonhuman mind, that of the bottlenose dolphin" (xi). Left indeterminate by this statement is whether or not—since the very possibility of bringing about the contemplated event in actual practice had not yet been determined—the scientific penetration to be achieved is *only* theoretical. For

² Heinz von Foerster to John C. Lilly, typescript dated October 24, 1967, Heinz von Foerster papers, University of Illinois at Urbana-Champaign.

³ John Cunningham Lilly, M.D., *The Mind of the Dolphin: A Nonhuman Intelligence* (Garden City, NY: Doubleday, 1967).

actual as opposed to theoretical penetration into a nonhuman mind would mean a successful instance of establishing interspecies communication through some as yet unknown or undiscovered relation by which that nonhuman mind would reveal its own thoughts to a human interlocutor in a mutually understandable medium. The eight-year-old project that *The Mind of the Dolphin* recounts in 1967 details the uncanny aspiration to achieve an unprecedented breakthrough beyond companionate communion to fully abstract linguistic communication across species boundaries.

Between 1959 and 1968 Lilly wagered and lost his mainstream scientific career largely over this audacious, ultimately inconclusive bid to establish and document for scientific validation “communication with a nonhuman mind” (xi). In that effort, however, he mobilized the best available tools, a cutting-edge array of cybernetic concepts. He leaned heavily on the information theory bound up with first-order cybernetics and operated with heuristic computational metaphors alongside the actual computers of his era. As I will elicit through some close readings of his texts, in that process Lilly also homed in on crucial epistemological renovations with a constructivist redescription of cognition that may have influenced and motivated his colleague von Foerster’s more renowned formulations, arriving in the early 1970s at a *second-order* cybernetics.⁴ In subsequent decades the discourse of second-order cybernetics —epitomized in the concept of autopoiesis—would provide Niklas Luhmann’s social systems theory a conceptual base for its own discourse of communication. I will call upon Luhmann’s work at times to compare with Lilly’s earlier cybernetic discourse of communication. Embedded in the cetology of *The Mind of the Dolphin*, then, is an exotic anthropology of 1960s cybernetics, centered on an overburdened notion of communication.⁵

Penetration

Much of the weight Lilly rested on his discourse of communication in *The Mind of the Dolphin* came from therapeutic concerns inculcated by his medical and

⁴ The classic text here is Heinz von Foerster, “On Constructing a Reality” (1973), in *Understanding Understanding: Essays on Cybernetics and Cognition* (New York: Springer, 2003), 211-27. See also Heinz von Foerster, *The Beginning of Heaven and Earth Has No Name: Seven Days with Second-Order Cybernetics*, eds. Albert Müller and Karl H. Müller, trans. Elinor Rooks and Michael Kasenbacher (New York: Fordham University Press, 2013).

⁵ On the modern overdetermination of the concept of communication, see John Durham Peters, *Speaking into the Air: A History of the Idea of Communication* (Chicago: University of Chicago Press, 1999).

psychoanalytic trainings. This background informed his presentation of research into interspecies communication as administering to goals of individual and collective mental health with cures for human pathologies of communication. For instance: “one’s own beliefs below his usual levels of awareness prevent complete communication with self and with other persons. Our species has not achieved equality of communication. . . . Communication with other peoples fails; we have international conflicts in most of the world” (xiii). However, the very breadth of Lilly’s discourse of communication generated its own problems of equivocation, and ultimately, of conceptual overreach. In the remark just above, “complete communication” would indicate not just serviceable understandings concerning basic social matters of shared concern. Rather, such “completion” ought to issue in an “equality” of agreement or consensus to the point of complete mutual understanding or spiritual communion. As social systems theory would lead one to expect, the overdetermined ideality of communication in Lilly’s treatment fomented equivocal oscillations between psychic and social references, amplified by putting “mind” and “communication” into such tight tandem without adequate conceptual means to account for their differentiation.

While ideals such as “equality of communication” underscored the liberal humanism residing in Lilly’s overt scientific rationales, they also indicated the difficulties built into his dream of equality for interspecies communication. For a bona fide “penetration” to occur, nothing less than an articulate exchange of interspecies intimacies would really do, and until that moment arrived, on the human end his research team could only keep faith in the hope that their project was possible:

If and when dolphins and we do establish communication on a highly abstract level, the proof will become obvious and incontestable. In this book I give some of the details of this developing picture and give the reasons why we, the ones who work with them, must rely for some time on our faith in their intelligence. *This faith is in the working hypothesis that both we and they are intelligent enough to break the interspecies communication barrier between these very different minds.* (84; emphasis in the original)

Lilly’s supersonic metaphor of the “interspecies communication barrier” offered an inappropriately material or physical image for the immaterial operational closures of the autopoietic systems that would have to be successfully coupled (not “broken” or “penetrated”) to yield the expanded social system that would result from an actual episode of interspecies communication. But what this metaphor did capture is the pathos of “penetration” when the object to be opened up is not precisely palpable—is not a brain, but a mind.

Let us pause to recall that Lilly began his scientific career as a neurophysiologist developing penetrative techniques for behavioral research on mammalian brains, culminating in papers of the later 1950s such as “Learning Elicited by Electrical Stimulation of Subcortical Regions in the Unanesthetized Monkey,” and “Learning Motivated by Subcortical Stimulation: The ‘Start’ and ‘Stop’ Patterns of Behavior.” As communication researcher John Shiga explains: “In these experiments, Lilly inserted electrodes into various regions of a monkey’s brain, sent electric current through the electrode, and recorded the animal’s behavior and its neurological activity. The implanted electrodes enabled Lilly to map neural networks and to link sensory events, muscle movements and other behaviors to patterns of activity in those networks.”⁶ The goal, then, to “scientifically penetrate into the area of at least one nonhuman mind” marks a transition from neurophysiological materiality to psychological intangibility. This metaphysical trend is uttered through a metaphorical statement, heavily laden with material-physiological connotations, not for the actual piercing of a material sheath or organic membrane but for the effective elaboration of a virtual communication medium by which to couple two different species in “complete” communication at a fully abstract level of meaning construction.

Projection

In Lilly’s efforts to craft not only theories but also experimental protocols for “complete communication” with dolphins, one difficulty was to establish the requisite controls against an observer’s misconstruing a random instance of cetacean phonation as a humanly meaningful abstract utterance. For human beings generally as well, “this problem of projection blocks a large fraction of true communication” (3). Projection short-circuits a proper understanding of what others are thinking or meaning to convey when they make a communicative offer. However, the paradox built into Lilly’s experimental situation can be said to take this form: unless you’ve already succeeded in communicating, you can’t even know the status of your attempts. Or again, without communication having already been established, how is one to ask the dolphin to confirm if one has understood it correctly the first time? Yet it would seem that in relation to interspecies communication, the problem of projection cannot be circumvented, it can only be controlled for by a trial-and-error protocol maintained at the human end until the moment arrives when the dolphin itself begins to assist in the correction process:

We use the following *working hypotheses* in our communication research with dolphins: The airborne whistles and the airborne

⁶ Shiga, “Of Other Networks.”

clicks are attempts to communicate with us as they do with one another, i.e., attempts to induce us to use their mode of communication. . . . Their humanoid sounds in air are their approximations to our communication sounds as distorted by their hearing and by their phonation apparatus. . . . *With the humanoid sounds, dolphins are attempting to communicate with us in our mode of communication.* (83; emphases in the original)

In his *Theory of Society*, Luhmann draws out the immanent improbability of any communication whatsoever. He notes that the extreme contingency of communicative success “is hardly ever posed so drastically” as one finds in his treatment of the topic: “the fact that a system of society actually exists and reproduces communication through communication . . . is extremely improbable. Only communication makes itself probable. . . . If the individual components of communication [information, utterance, understanding] are in themselves improbable, their synthesis is all the more so” (1:113-14). Applying Luhmann’s theoretical descriptions to Lilly’s project, the higher improbability of interspecies communication would also follow from the higher incommensurability of alien *psychic* systems, the radical difference of which would tend to deter the formation of any medium of meaning to which a hybrid, interspecies social system could couple itself such that human and dolphin individuals could arrive at commensurate understandings of communicative offers. And here again is a formulation of the Catch-22 or logical quandary in which Lilly’s project is caught: only interspecies communication could make interspecies communication probable. In the human instance, the communications produced by social systems have had eons to evolve in coevolutionary step with neurological and psychic systems. Can the formation of an interspecies social system really be jumpstarted in a few weeks or years, especially when one species is landborne and the other aquatic? Talk about the improbability of communication! Lilly’s immanently improbable effort can proceed only on the prayers (since while any conclusive evidence for these assumptions may be “developing,” it has not yet arrived) that the nonhuman beings to be communicated with are comparably communicative within their own societal forms, and moreover, that interspecies communication is not just possible but *desired* on both sides of the potential exchange. In other words, to gain any traction at all, Lilly must force the issue. His project must be built on the projection of its desired outcome:

We must keep the working hypothesis in mind that “they are highly intelligent and are just as interested in communicating with us as we are with them.”. . . If we use any other hypothesis, we have no success whatsoever in dealing communicatively with them. This hypothesis seems to be necessary and even overriding

to accomplish the kinds of communication we are accomplishing and attempting to expand. The proof, the incontrovertible truth, that they are interested in this communication is developing slowly and carefully in our laboratory. (83)

And in any event, as Lilly goes on to assert, the mechanism behind the problem of projection—the psychic generation of mental models—is also at the root of cognition altogether. In line with the cybernetic vogue of the 1960s, Lilly endows that central mechanism with a fully mechanistic description. Complementing his implicitly cybernetic focus on communication, Lilly introduces an explicit computational analogue for the mammalian brain. Like a computer programmed to simulate a real-world process, that brain generates models for the mind to use, and at times, misuse. Addressing the matter of projection, he asks “How do we do this wishful, false realizing? Our relatively large minds (brains) act as computers that can make models inside themselves of other human minds and their activities” (3). Now, social systems theory would redescribe the matter of projection in a post-computational manner, as a normal problem set of observation and attribution for operationally closed meaning systems. Projection is a momentary or prolonged negation of internal or self-reference in favor of an uncorroborated external or hetero-referential attribution. Moreover, in first-order observation, self-reference is blocked as a matter of course.⁷ That is, psychic events arise altogether as internal or systemic selections that the mind can check for referential consistency only by participating in society and thus enabling others to form and communicate second-order observations as corrective or affirmative responses to one’s own utterances.

Returning to Lilly’s psychic cybernetics, we are informed that only specific areas of the brain are “hard wired” for specific tasks, while much of it is “general purpose”: this readiness for variable programming “is the saving grace which allows one individual to communicate with another. . . . The important common power is the ability of this brain to assume the tasks of making models of creatures and persons in its surrounds. This is the fundamental property which allows communication to take place” (7). Lilly bases this theorization of communication upon a loosely specified ability of the brain to “take on” the commonality of communication’s semiotic medium—language: “We can develop and share a language among uniquely different individuals because each of those individuals can take on enough of the commonality of language within his own brain to allow communication” (7). And yet the commonality of language immediately runs up against the privacy of thought: “But we must never forget that the thinking processes of the individual are still uniquely his or hers. Only

⁷ See Niklas Luhmann, *Theory of Society, Volume 1*, trans. Rhodes Barrett (Stanford: Stanford University Press, 2012), 49.

certain aspects are common and shared” (7). Which aspects? Well, language. Lilly does the best he can with the psycholinguistics he has at hand, but his theory cannot break out of the mere circularity of these formulations. Still, his intuition for the closure of consciousness is properly presented. Lilly rightly insists on the impossibility of penetrating to the possession of a fellow human’s thoughts: “We may have the illusion of penetrating completely into the mental life of another human being through language, but this is impossible. Each of us is so uniquely different and so uniquely himself that we cannot yet so penetrate” (7). And these considerations of the limits of human knowledge are then to be pointed toward the problem of the absolutely alien mind of the dolphin.

As we have already noted, the theoretical penetration of the mind of the dolphin Lilly introduced in his preface does not mean any material or spiritual seizure of its contents but rather, simply but decisively, the establishment of a relation of communication. Any mind is black-boxed, self-possessed of an inviolable mental privacy whose only inlets and outlets depend upon events of communicative reception and utterance. It is in this context that Lilly obliquely introduces into his dolphin discourse the deep background of his experimentation with the isolation tank.⁸

No one wants to be insulated and isolated for long from his fellow human beings. In experiments in which I have isolated volunteer subjects and in experiences in which others have isolated themselves, it is shown that the major need that develops in the isolation experience is transactions with others, i.e., communication. This need can be temporarily satisfied by hallucinating and talking to the “projected” persons in the solitudinous surroundings. (8)

With this allusion to the isolation tank, the topic of projection recurs in his text not as a pathology of communication but rather as a sort of involuntary protective reflex, an affective-ideational immune response. The isolation tank provides a literal materialization of the operational closure of the psychic system, momentarily structurally decoupled from any possibility of “true” communication. When you are in the tank, no one can hear you communicate. And so, hallucinatory projection provides an emergency solution to the terrors of extreme isolation by intuiting companionship to counter the momentary impossibility of communication. In Lilly’s cybernetic idiom, and especially as induced by immersion within an isolation tank, hallucinations are particular projective phenomena that compute internal models of outer things and then insert

⁸ For a detailed and thoughtful overview of this topic, with reference to a recent revival of its scientific application, see Langlitz, “Tripping in Solitude.”

them into a larger model of the mind's external environment. The mind in artificial isolation invents and populates its own world, similar to or different than the world outside the tank, but in any event without recourse to the usual consistency checks of actual communication.

Self-Reference

If Lilly himself were to be the first human explorer to make contact across the species boundary to the mind of the dolphin, he could not at the same time stand outside the circuit of communication he hoped to achieve. In his current experimental sphere of sentient encounter between large-brained mammals, any traditional methodological move to remove himself from the stage of his experimental theater would create “paradoxes. Man himself must be included. The scientist himself must be in his system” (28). Lilly’s statement anticipates the self-referential turn that second-order cybernetics will soon generalize to all occasions of observation. But by acknowledging the experimenter’s presence within the system to be observed, he is not so much escaping from paradox as presciently engaging with the basal paradox of observing systems as that will be codified in second-order systems theory.⁹ From the positivist point of view of normal science, of course, Lilly draws paradox to himself just by entering the circle of his own experiment and so collapsing any stance of objective detachment. Nonetheless, Lilly remained fastidious in maintaining an awareness of methodological distinction between hetero- and self-reference, in this instance, between “fact and theory”: “In my work as a generalist, I use the model of the physicists and their separation rule. I separate the fact and theory rigorously in my own mind. In addition, experimenter and the parts of himself functioning in the system under investigation are separated as far as is practical” (29). Nonetheless, in order to perform this notional separation he can only step once more into the circle of paradox, holding together in his own person the unity of the distinction between self- and hetero-observation.

Lilly’s observational paradox is only compounded in this text written for a general audience by his desire both to share and to guard the revelatory experiences that are backstage-managing the self-referential renovations to his scientific practice:

If one succeeds in having a religious revelation, the significance is steeped in a perspective so vast as to generate an awe from which

⁹ See Niklas Luhmann, “The Paradox of Observing Systems,” in *Theories of Distinction: Redefining the Descriptions of Modernity*, ed. William Rasch (Stanford: Stanford University Press, 2002), 73-93.

he cannot recover. . . . Such experiences are not yet admitted to the halls of conventional science. A major difficulty is that unless another person has had such experience, he cannot share the wonder and the awe of one's own inner experiences. . . . The truth of what one presents is not subject to the usual tests of evidence as devised in the courts and the sciences. (35-36)

Although unspoken as yet in this text, Lilly labors here to contain his LSD experiences, begun in 1964, within the proprieties of standard objective discourse. Communication of this sort is another problem constituted by the closure of individual experience, especially for those private experiences that permanently alter one's relation to the world. Understanding of the revelatory information that he could utter greatly depends on the mental and experiential preparation of its recipient. In this manner the problematics of interspecies and intraspecies communication intersect.

One rhetorical strategy Lilly develops in this text for rendering impersonal information about himself is his recourse, however strained, to a third-person stance. Another such strategy—concurrently undergoing full development in *Programming and Metaprogramming in the Human Biocomputer*—is the coupling of that expository voice to an idiom and conceptual allegory steeped in cybernetics. Channeling his personal experiences and theoretical stances through the affectless tones of classical computerese nicely induces a scientific flattening of the delivery. For instance:

In this theoretical view which we are generating, theories are analogous to computer metaprograms. One's own brain is analogous to a huge computer larger than any built today. The theories (programs and metaprograms) stored in one's self operate the way a stored program in a modern computer operates. The stored program gives the orders for the data acquisition, the computations to be done, the logic to be used, the models to employ, the new models to be constructed, the end use of the results, and the outputs to be chosen to carry out the end uses. Thus, to test a given theory, one "programs" himself with the as-complete-as-possible theory and joins the system under investigation as a participant-computer operating "on line." (92)

The self-referential element returns in the self-programming of the "scientist in the system" as a "participant computer" running a theoretical metaprogram to be put to the experimental test in real time. If one discounts the earnest intentions at play in this edgy science, Lilly might as well be composing a posthuman strain of performance art. Let us call it *experimental performance science*, in which, in this cybernetic milieu, the experimenter self-fashions himself not just as a participant

observer but as a computational device coupled into the system to be observed, open to on-line learning and real-time reprogramming and, as prophylaxis against projection, impervious to emotional distraction: “*one streamlines himself for the program*. If one is going to be a participant computer, he must get rid of excess emotional baggage. Excessive guilt has to be eliminated. Personal blind spots and tender pain-shame areas must be changed or erased. The model of the computer itself which one is striving for contains no personal blocks against finding the truth no matter where it lies” (95).

Redefining Information

Chapter 4 of *The Mind of the Dolphin* is titled “Communication Is between Minds.” The crucial distinction implied by this statement is that communication is not merely between *brains*. It is not simply a matter of sequential sensory-neurological transmissions and receptions. The threshold of mind arrives with the higher-order computations that allow for metaprogramming and general-purpose modeling. The definition of communication now receiving explicit statement works backward from this distinction of mind:

Definition: *Communication is the exchange of information between two or more minds.* (99)

Nonetheless, as the term “exchange” indicates, Lilly’s scheme of communication comes out of an informatic matrix still wedded to a data-transmission model. Lilly provides a diagram directly adapting the famous diagram of a communication system in Warren Weaver’s introduction to his and Claude Shannon’s *Mathematical Theory of Communication*.¹⁰ Nonetheless, key differences emerge from their comparison. The interest for us will be in the ways that Lilly, for one, finesses classical information theory in order to open up a conceptual residence for *mind* (an entity seldom elicited in standard informatic discourse), and for another, provides some preliminary sketches for a constructivist epistemology.

¹⁰ Warren Weaver, “Recent Contributions to the Mathematical Theory of Communication,” in Warren Weaver and Claude Shannon, *The Mathematical Theory of Communication* (Urbana: University of Illinois Press, 1949), 3-28.

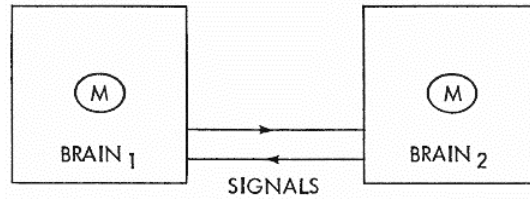

Figure 1 – John Lilly’s Schema of the Definition of Communication in *The Mind of the Dolphin*

Regarding his schema of communication, Lilly explains: “This diagram shows a mind (M) on the left in the circle contained in brain 1 (the square) transmitting signals to mind (M) in the circle on the right contained within brain 2, the square. In turn, mind 2 is sending signals to mind 1” (102). Compare Warren Weaver’s diagram of information transmission:

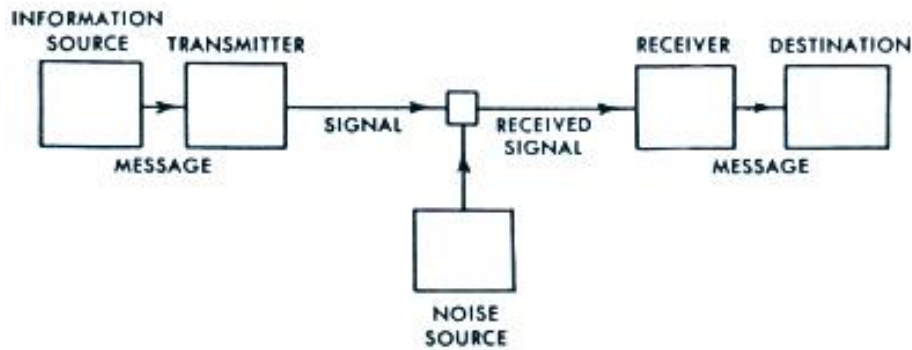

Figure 2 – Warren Weaver’s diagram of information transmission from *The Mathematical Theory of Communication*

Information theory per se is oriented to technological systems. Weaver’s diagram is modeled on a telephone system and focuses on signal conversion, signal load, and signal loss, for which depiction a one-way transmission suffices. Lilly’s diagram is ostensibly oriented to embodied minds and depicts a minimal social system—in Luhmann’s idiom, an interaction system. At the same time, his brain-mind composites are also, at least in the heuristics of his theory, *biocomputers*, and this psychophysiology comes forward in a strongly cybernetic frame. Thus Lilly’s diagram can be unfolded toward Shannon and Weaver’s technological scheme by momentarily positing the mind in brain 1 as the information source, the mind in brain 2 as the destination, and brains 1 and 2 as the neurological aspects of signal transmission and reception respectively. However, as Lilly

operates his diagram, the key turn is this: “The information is not generated from these signals until the signals are received, computed, and turned into the information by each of the minds in turn. This is the essential core of our definition of communication” (102-3).

Purveying a common equivocation in communication theory, what Lilly here terms *information* is more precisely the *meanings* constructed by either mind as a result of their social “exchange.” Since he is still working in a first-order informatic idiom, Lilly deploys an equivalent distinction between “signal” and “information.” However, in importing the brain-mind couple into the informatic diagram, and in drawing a circle around mind relative to the brain, Lilly’s scheme adumbrates a constructivist or second-order distinction between information and meaning. Perhaps I am projecting what I want to find, but it seems to me that by introducing *mind* into his scheme and so “placing new boundaries on information theory” (105), Lilly’s biocomputational model posits a strong anticipation of the operational boundaries to be codified in Luhmann’s metabiotic appropriation of autopoiesis for the production of consciousness and communication in psychic and social systems:

The *information* does not exist as information until it is within the higher levels of abstraction of each of the minds and computed as such. . . . Information is the result of a long series of computations based on *data signal inputs, data signal transmissions to the brain substance, and recomputations of these data.* . . . The schema of the definition shows that one must differentiate very carefully between “signals” and “information.” In this view, a set of signals . . . is not information; *it becomes so only if and when it enters, is computed, and changes the contents of a mind.* . . . In other words, our boundary for information is at a level of discourse of *Cogito ergo sum*, “I think (or I know), therefore I am.” *Information is that which I know now, coming from outside me, and coming from the storage inside me, allowing for delays in computation and in transmission.* . . . The mind of the observer-participant is where the information is constructed, by and through his own programs, his own rules of perception, his own cognitive and logical processes, his own metaprogram of priorities among programs. (103-4; emphases in the original)

The Signal-Noise Ratio

With the inscription of the “observer-participant” into the interactive construction of meaningful information for communicative exchange between minds, Lilly now elicits the component of informatic noise left over from the Warren Weaver diagram of information flow. But unlike their simple addition of a noise source to signal transmission, Lilly imports and distributes information theory’s signal/noise ratio across his scheme of communication: “the signal/noise ratio is a definable entity only when each of two minds agrees on the definition of what is ‘signal’ and what is ‘noise’” (105).¹¹ However, having underscored that communication demands social agreement on how to distinguish meaningful forms from the randomness of their medium, Lilly now focuses on the individual mind’s self-generation of meaning forms, and his train of exposition arrives once more at the station of physical isolation inducing psychic projection as a source of mental formations. Given a prolonged contemplation of a noisy process, one may begin to “‘make signals out of the noise’ by introducing systematic changes into the noise. In profound physical isolation, this process can be shown most dramatically. *Our minds project a pattern onto the noise.* . . . Basically, investigators who are looking into their own minds (under special conditions) may mistake the sources of ‘new’ information within their own minds as if those sources were outside the head. This process in psychology is called ‘projection’” (105-6).

In the context of the research protocols for the scientific practices under discussion in *The Mind of the Dolphin*, once again, projection is basically a problem, not simply insofar as it may corrupt the experiential data being collected and examined, but also insofar as one may be tempted to contemplate a hypothesis that hallucinated messages are in fact offers of communication arriving through unknown, immaterial channels. Here in some of the weirdest passages of this text, Lilly darkly intimates, although in the mode of rational negation, that communication with dolphins could conceivably occur—especially if all efforts at normal symbolic exchange yield a null result—through a paranormal or telepathic medium:

If one is watching “noise” at the logical level, he can sometimes “hear messages,” as if he were being spoken to by other persons and these persons were telling him some important message...

¹¹ Lilly’s exposition of noise makes his equation between meaning and information explicit: “In the standard theory, ‘noise’ . . . is a form of energy in which no part can be taken, no matter how chosen, as conveying any meaning whatsoever. Physical noise is that set of signals which, when received by a mind, generates no new information in that mind” (105).

Fundamentally, then, we must eliminate, insofar as our brains and minds and their scientific investigation are concerned, a hypothesis which says that the noise coming from inside one's own mind and brain can be "signals caused by direct mental influence of other minds without the interposition of the usual modes and media of communication." (106)

Lilly continues for a number of pages in this vein of the logical dismissal of as well as denial of evidence for uncanny communication, ostensibly to underscore the comprehensive reach of his theorizations and rigor of his experimental procedures. He arrives at a declaration of practical agnosticism: "My own position about religion is the same as my position about ESP ["extra-sensory perception"] and thought transference. Until I have empirical, down-to-earth, hard-nosed information thrust upon me, I will maintain a position of not knowing; such thinking also belongs in the area of the unknown" (110).

Nonetheless, at this point in the text a reader could still wonder why Lilly wants to take his discussion on a long detour into such outlandish matters. *The Mind of the Dolphin* does not really answer that question, although a bit later, in chapter 5, the essential clue is given when Lilly provides a short work-up of the parallel research project that has been moving in and out of focus between the lines of this text. Now shifting into a first-person narration, he remarks that "after many exposures to the physical isolation under ideal physical conditions, I was able to overcome self-created mental discomfort to a certain extent. I learned a lesson about our minds as follows: Our huge computers are, to a certain extent, self-metaprogramming and self-programming" (121). Right here Lilly provided a footnote to an early version of the second book-length text he completed in 1967. This was the obligatory final research report composed at the conclusion of his five-year Career Award from the National Institutes of Mental Health (NIMH), which award had been largely financing the CRI since 1962. In Lilly's footnote, the title is given as *The Human Biocomputer: Programming and Metaprogramming (Theory and Experiments with LSD-25)*.¹²

An extended consideration of this major intertext must wait for another occasion. Instead, by way of conclusion for the moment, I will move directly to a section of *Programming and Metaprogramming* that overlaps some key topics we have been tracking through the discourse of communication in *The Mind of the Dolphin*. In particular, we will look at some passages from chapter 8, "Basic Effects of LSD-25 on the Biocomputer: *Noise* as the Basic Energy for Projection

¹² Lilly addresses this work's "curious history" in his 1972 foreword to the second edition of *Programming and Metaprogramming in the Human Biocomputer: Theory and Experiments* (New York: Bantam, 1974), v. I will quote the text from this 1974 edition.

Techniques.” The wording of the title indicates the crux of the difference between the two treatments. In the dolphin book, invested in the maintenance of a baseline of normal scientificity, projection is presented primarily if not entirely as a source of aberration in the data collected, a problem factor to be controlled. But what Lilly discovered and subsequently explored in the isolation work was that, depending on the kind of experiment one had in mind, projection need not be controlled *for* but simply itself controlled as a research *technique*. All the more so under the radical suggestibility induced by LSD, projection offered a phenomenological resource that could itself be “programmed” and so tested experimentally for the purpose of sounding the limits of possible belief.

In the following passages from *Programming and Metaprogramming*, Lilly adverts to the signal/noise ratio, but with some major differences. Whereas in the dolphin book, the noise source was located “in the external world . . . by either looking at a very noisy visually presented process or by listening to a very noisy acoustically presented process” (105), in the biocomputer text, the noise source is fully internalized. It is in fact the form of the contribution LSD makes, an amplification of “the *noise level of the mind itself*” (82):

In the analysis of the effects of LSD-25 on the human mind, a reasonable hypothesis states that the effect of these substances on the human computer is to introduce *white noise* (in the sense of randomly varying energy containing no signals of itself) in specific systems in the computer. . . . The major operative principle seems to be that **the human computer operates in such a way as to make signals out of noise and thus to create information out of random energies where there was no signal**; this is the “projection principle”; noise is creatively used in non-noise models. (80-82; emphasis in the original).

Later on the same page Lilly introduces a long passage from a 1962 paper by Heinz von Foerster, “Bio-Logic,” in order to cite the latter’s argument for the hypothesis that some percentage “of all operations in the brain are afflicted with an intrinsic noise figure which has to be taken care of in one way or another” (83).¹³ But let us also jump forward for a moment to von Foerster’s justly famous 1974 paper “On Constructing a Reality,” to sample what may be its own reciprocating of Lilly’s attention. A section on “Computation” ends with the observation that “In ‘biological computers’ the programs may themselves be computed on. This leads to the concepts of ‘metaprograms,’ ‘meta-

¹³ Lilly cites from Heinz von Foerster, “Bio-Logic,” in *Biological Prototypes and Synthetic Systems*, volume 1, eds. Eugene E. Bernard and Morley R. Kare (New York: Plenum Press, 1962), 1-12.

metaprograms,' and so on. This, of course, is the consequence of the inherent recursive organization of these systems" (224). The following section on "Closure" formulates a "postulate of cognitive homeostasis" that reads like a straightforward generalization of the bio-computational principle underlying the statements Lilly's text placed in bold font above. Von Foerster writes: "The nervous system is organized (or organizes itself) so that it computes a stable reality" (225).

The postulate of cognitive homeostasis would of course hold, as much as may be possible, under relatively extreme conditions such as LSD's amplification of the white noise perceived by the mind amidst any other signals. And so, as Lilly lists off the basic effects of LSD-25 on the biocomputer, "One can thus 'explain' the apparent speed-up of subjective time; the enhancement of colors and detail in perceptions of the real world; the production of illusions; . . . the projection of emotional expression onto other real persons; the synesthesia of music to visual projections; the feeling of 'oneness with the universe'; apparent ESP effects; communications from 'beings other than humans'" (80). While caution over seduction by misconstrued projections remains, in *Programming and Metaprogramming* the projection process itself becomes an openly and open-endedly self-experimental technique, a voluntary search for the limits of mental experience that the adept metaprogrammer of one's own biocomputer (brain) can induce: "One can . . . detect the *noise level of the mind itself* and use it for cognitional projections rather than sense-organ-data projections" (82).

Put another way, projection is a problem only if the goal being sought is communication in an interaction system, such as that constellated by the interspecies effort. In the end, communication research with dolphins ran aground against its own improbability, not to mention Lilly's increasingly precipitous loss of institutional support as the outlandish aspects of his dolphin work came to loom larger than its initial promise and appealing pathos.¹⁴ Once Lilly turned the "projection principle" from a side-effect into a primary technique for self-experimentation on the limits of belief, the matter of communication was no longer the object of the science but simply the process of its symbolically-mediated presentation beyond the self. If Lilly's proactive treatment of "cognitional projections" upon the noise of the mind directly anticipated some aspects of von Foerster's mature contribution to the discourse of systems theory, the epistemological constructivism of second-order cybernetics, it did so in an activist mode of psychic exploration, a mode that the necessary protocols of communication research could only hinder and impede. Ever the intellectual sophisticate, von Foerster successfully moderated and streamlined the more outré

¹⁴ For copious detail on this score, see Burnett, *Sounding of the Whale*, chapter 6.

elements of his friend Lilly's psychonautical adventures, extracting their gist and making it eventually into a resource for social systems theory's autopoietic coupling of the discourses of consciousness and communication.

Bibliography

- Burnett, D. Graham. *The Sounding of the Whale: Science and Cetaceans in the Twentieth Century*. Chicago: University of Chicago Press, 2012.
- Langlitz, Nicolas. "Tripping in Solitude: Introducing Honza Samotar by Way of John Lilly." In Katrin Solhdju, ed. *Introspective Self-Rapports: Shaping Ethical and Aesthetic Concepts 1850–2006* (Preprint 322). Berlin: Max Planck Institute for the History of Science, 2006, 81-92.
- Langlitz, Nicolas. *Neuropsychedelica: The Revival of Hallucinogen Research since the Decade of the Brain*. Berkeley: University of California Press, 2013.
- Lilly, John Cunningham, M.D. *The Center of the Cyclone: An Autobiography of Inner Space*. New York: Julian Press, 1972.
- Lilly, John Cunningham. *The Mind of the Dolphin: A Nonhuman Intelligence*. Garden City, NY: Doubleday, 1967.
- Lilly, John Cunningham. *Programming and Metaprogramming in the Human Biocomputer: Theory and Experiments*. New York: Bantam, 1974.
- Lilly, John Cunningham. *The Scientist: A Novel Autobiography*. Philadelphia and New York: J. B. Lippincott, 1978.
- Lilly, John Cunningham. and Antonietta Lilly. *The Dyadic Cyclone: The Autobiography of a Couple*. New York: Simon and Schuster, 1976.
- Luhmann, Niklas. "The Paradox of Observing Systems." *Theories of Distinction: Redescribing the Descriptions of Modernity*. Ed. William Rasch. Stanford: Stanford University Press, 2002. 73-93.
- Luhmann, Niklas. *Theory of Society, Volume 1*. Trans. Rhodes Barrett. Stanford: Stanford University Press, 2012.
- Peters, John Durham. *Speaking into the Air: A History of the Idea of Communication*. Chicago: University of Chicago Press, 1999.
- Pruchnic, Jeff. "Neurorhetorics: Cybernetics, Psychotropics, and the Materiality of Persuasion." *Configurations* 16: 2 (Spring 2008).
- Shiga, John. "Of Other Networks: Closed-World and Green-World Networks in the Work of John C. Lilly," *Amodern 2: Network Archaeologies*, <http://amodern.net/article/of-other-networks/>.
- von Foerster, Heinz. *The Beginning of Heaven and Earth Has No Name: Seven Days with Second-Order Cybernetics*. Eds. Albert Müller and Karl H. Müller. Trans. Elinor Rooks and Michael Kasenbacher. New York: Fordham University Press, 2013.

von Foerster, Heinz. "Bio-Logic," in *Biological Prototypes and Synthetic Systems*, volume 1. Eds. Eugene E. Bernard and Morley R. Kare. New York: Plenum Press, 1962. 1-12.

von Foerster, Heinz. "On Constructing a Reality" (1973) In *Understanding Understanding: Essays on Cybernetics and Cognition*. New York: Springer, 2003. 211-27.

von Foerster, Heinz. Letter to John C. Lilly, October 24, 1967. Typescript. Heinz von Foerster papers, University of Illinois at Urbana-Champaign.

Weaver, Warren. "Recent Contributions to the Mathematical Theory of Communication." In Claude Shannon. *The Mathematical Theory of Communication*. Urbana: University of Illinois Press, 1949. 3-28.